

ANNEX I
SUMMARY OF PRODUCT CHARACTERISTICS

▼ This medicinal product is subject to additional monitoring. This will allow quick identification of new safety information. Healthcare professionals are asked to report any suspected adverse reactions. See section 4.8 for how to report adverse reactions.

1. NAME OF THE MEDICINAL PRODUCT

Enspryng 120 mg solution for injection in pre-filled syringe

2. QUALITATIVE AND QUANTITATIVE COMPOSITION

Each pre-filled syringe (PFS) contains 120 mg of satralizumab in 1 mL.

Satralizumab is produced in Chinese hamster ovary cells by recombinant DNA technology.

For the full list of excipients, see section 6.1.

3. PHARMACEUTICAL FORM

Solution for injection (injection)

Colourless to slightly yellow liquid. The solution has a pH of approximately 6.0 and an osmolality of approximately 310 mOsm/kg.

4. CLINICAL PARTICULARS

4.1 Therapeutic indications

Enspryng is indicated as a monotherapy or in combination with immunosuppressive therapy (IST) for the treatment of neuromyelitis optica spectrum disorders (NMOSD) in adult and adolescent patients from 12 years of age who are anti-aquaporin-4 IgG (AQP4-IgG) seropositive (see section 5.1).

4.2 Posology and method of administration

Treatment should be initiated under the supervision of a physician experienced in the treatment of neuromyelitis optica (NMO) or NMOSD.

Posology

Enspryng can be used as a monotherapy or in combination with oral corticosteroids (OCs), azathioprine (AZA) or mycophenolate mofetil (MMF) (see section 5.1). The posology in adolescent patients ≥ 12 years of age with body weight ≥ 40 kg and adult patients is the same.

Loading doses

The recommended loading dose is 120 mg subcutaneous (SC) injection every two weeks for the first three administrations (first dose at week 0, second dose at week 2 and third dose at week 4).

Maintenance doses

The recommended maintenance dose is 120 mg SC injection every four weeks.

Duration of treatment

Enspryng is intended for long-term treatment.

Delayed or missed doses

If an injection is missed, for any reason other than increases in liver enzymes, it should be administered as described in table 1.

Table 1: Recommended dosage for delayed or missed doses

Last dose administered	Recommended dosage for delayed or missed doses
Missed a loading dose or less than 8 weeks during the maintenance period	<p>The recommended dose should be administered as soon as possible without waiting until the next planned dose.</p> <p><u>Loading period</u></p> <p>If the second loading dose is delayed or missed, this dose should be administered as soon as possible and the third and final loading dose 2 weeks later.</p> <p>If the third loading dose is delayed or missed, this dose should be administered as soon as possible and the first maintenance dose 4 weeks later.</p> <p><u>Maintenance period</u></p> <p>After the delayed or missed dose is administered, the dosing schedule should be reset to every 4 weeks.</p>
8 weeks to less than 12 weeks	The recommended dose should be administered at 0*, 2 weeks and every 4 weeks thereafter.
12 weeks or longer	The recommended dose should be administered at 0*, 2, 4 weeks and every 4 weeks thereafter.

* “0 weeks” refers to time of the first administration after the missed dose.

Dose modification advice for liver enzyme abnormalities

If the alanine aminotransferase (ALT) or aspartate transaminase (AST) elevation is >5 x upper limit of normal (ULN) and associated with any bilirubin elevation, treatment must be discontinued, and reinitiation is not recommended.

If the ALT or AST elevation is >5 x ULN and not associated with any bilirubin elevation, treatment should be discontinued. Treatment can be restarted at a dose of 120 mg SC injection every four weeks when the ALT and AST levels have returned to the normal range and based on assessment of benefit-risk of treatment in the patient. If the decision is taken to restart treatment, liver parameters must be closely monitored, and if any subsequent increase in ALT/AST and/or bilirubin is observed, treatment must be discontinued, and reinitiation is not recommended (see sections 4.4 and 4.8).

Table 2: Recommended dose for restart of treatment after liver transaminase elevation

Last dose administered	Recommended dose for restart of treatment
Less than 12 weeks	Treatment should be restarted using the recommended dose, given every 4 weeks.
12 weeks or longer	Treatment should be restarted using the recommended dose, given at weeks 0*, 2, 4 and every 4 weeks thereafter.

* “0 weeks” refers to time of the first administration after the restart of treatment.

Dose modification advice for neutropenia

If the neutrophil count is below $1.0 \times 10^9/L$ and confirmed by repeat testing, treatment should be interrupted until the neutrophil count is $>1.0 \times 10^9/L$.

Dose modification advice for low platelet count

If the platelet count is below $75 \times 10^9/L$ and confirmed by repeat testing, treatment should be interrupted until the platelet count is $\geq 75 \times 10^9/L$.

Special populations

Paediatric population

The posology in adolescent patients ≥ 12 years of age with body weight ≥ 40 kg and adult patients is the same (see sections 5.1 and 5.2). The safety and efficacy of satralizumab in children with body weight < 40 kg have not yet been established. No data are available.

Elderly

No dose adjustment is required in patients ≥ 65 years of age (see section 5.2).

Renal impairment

The safety and efficacy of satralizumab have not been formally studied in patients with renal impairment. No dose adjustment is recommended for patients with mild renal impairment (see section 5.2).

Hepatic impairment

The safety and efficacy of satralizumab have not been studied in patients with hepatic impairment. No data are available (see section 5.2).

Elevations of liver enzymes have been observed during treatment with satralizumab (see sections 4.4 and 4.8). For dose adjustment, see above section Dose modification advice for liver enzyme abnormalities.

Method of administration

Satralizumab 120 mg is administered by SC injection using a single-dose PFS. The total content (1 mL) of the PFS should be administered.

The recommended injection sites are the abdomen and thigh. Injection sites should be rotated and injections should never be given into moles, scars, or areas where the skin is tender, bruised, red, hard, or not intact.

Comprehensive instructions for the administration of satralizumab are given at the end of the package leaflet.

Administration by the patient and/or caregiver

The first injection must be performed under the supervision of a qualified Healthcare Professional (HCP).

After adequate training on how to prepare and perform the injection, an adult patient/caregiver may administer all other doses at home if the treating physician determines that it is appropriate and the adult patient/caregiver can perform the injection technique.

Patients/caregivers should seek immediate medical attention if the patient develops symptoms of serious allergic reactions and should check with their HCP to confirm whether treatment can be continued or not.

4.3 Contraindications

Hypersensitivity to the active substance or to any of the excipients listed in section 6.1.

4.4 Special warnings and precautions for use

Traceability

In order to improve traceability of biological medicinal products, the name and the batch number of the administered product should be clearly recorded.

Infections

Administration of satralizumab should be delayed in patients with an active infection until the infection is controlled (see section 4.2).

Vigilance for the timely detection and diagnosis of infection is recommended for patients receiving treatment with satralizumab. Treatment should be delayed in case the patient develops any serious or opportunistic infection and appropriate therapy should be initiated under further monitoring. Patients should be instructed on seeking early medical attention in case of signs and symptoms of infections to facilitate timely diagnosis of infections. Patients should be provided with a patient alert card.

Vaccinations

Live and live-attenuated vaccines should not be given concurrently with satralizumab as clinical safety has not been established. The interval between live vaccinations and initiation of satralizumab treatment should be in accordance with current vaccination guidelines regarding immunomodulatory or immunosuppressive agents.

No data are available on the effects of vaccination in patients receiving satralizumab. It is recommended that all patients be brought up to date with all immunisations in agreement with current immunisation guidelines prior to initiating satralizumab treatment.

Liver enzymes

Mild and moderate elevations of liver transaminases have been observed with satralizumab treatment, most elevations were below 5 x ULN (see section 4.8).

ALT and AST levels should be monitored every four weeks for the first three months of treatment, followed by every three months for one year, thereafter as clinically indicated.

Treatment with satralizumab should be discontinued in patients with ALT or AST >5 x ULN (see section 4.2).

Neutrophil count

Decreases in neutrophil counts have occurred following treatment with satralizumab (see section 4.8). Neutrophil counts should be monitored 4 to 8 weeks after start of treatment and thereafter as clinically indicated. For recommended dose interruption see section 4.2.

4.5 Interaction with other medicinal products and other forms of interaction

No interaction studies have been performed.

Population pharmacokinetic (PK) analyses did not detect any effect of azathioprine (AZA), oral corticosteroids (OCs) or mycophenolate mofetil (MMF) on the clearance of satralizumab.

Both *in vitro* and *in vivo* studies have shown that the expression of specific hepatic CYP450 enzymes (CYP1A2, CYP2C9, CYP2C19, and CYP3A4) is suppressed by cytokines such as IL-6.

Therefore caution should be exercised when starting or discontinuing satralizumab treatment in patients also receiving substrates of CYP450 3A4, 1A2, 2C9 or 2C19, particularly those with a narrow therapeutic index (such as warfarin, carbamazepine, phenytoin and theophylline), and doses adjusted if needed.

Given the prolonged terminal half-life of satralizumab, the effect of satralizumab may persist for several weeks after stopping treatment.

4.6 Fertility, pregnancy and lactation

Pregnancy

There are no data from the use of satralizumab in pregnant women. Studies in monkeys do not indicate harmful effects with respect to reproductive toxicity (see section 5.3).

As a precautionary measure, it is preferable to avoid the use of Enspryng during pregnancy.

Breast-feeding

It is unknown whether satralizumab is excreted in human breast milk. Human IgG is known to be excreted in breast milk during the first days after birth, which is decreasing to low concentrations soon afterwards; consequently, a risk to breast-fed infants cannot be excluded during this short period. Afterwards, use of Enspryng could be considered during breast-feeding only if clinically needed.

Fertility

No clinical data are available on the effect of satralizumab on human fertility. Animal studies showed no impairment of male or female fertility (see section 5.3).

4.7 Effects on ability to drive and use machines

Enspryng has no or negligible influence on the ability to drive and use machines.

4.8 Undesirable effects

Summary of the safety profile

The most frequently reported adverse reactions observed were: headache (19.2%), arthralgia (13.5%), white blood cell count decreased (13.5%), hyperlipidaemia (13.5%), and injection-related reactions (12.5%).

Tabulated list of adverse reactions

Table 3 summarises the adverse reactions that have been reported in association with the use of satralizumab as a monotherapy or in combination with IST in clinical trials.

Adverse reactions from clinical trials (Table 3) are listed by MedDRA system organ class. Adverse reactions are presented using number of adverse events per 100 patient years and by frequency figures. The corresponding frequency category for each adverse reaction is based on frequency figures and the following convention: very common ($\geq 1/10$), common ($\geq 1/100$ to $< 1/10$), uncommon ($\geq 1/1,000$ to $< 1/100$), rare ($\geq 1/10,000$ to $< 1/1,000$), very rare ($< 1/10,000$).

Table 3: Adverse reactions

System Organ Class	Frequency	
	Very common	Common
Blood and lymphatic system disorders		Hypofibrinogenaemia
Metabolism and nutrition disorders	Hyperlipidaemia	
Psychiatric disorders		Insomnia
Nervous system disorders	Headache	Migraine
Cardiac disorders		Bradycardia
Vascular disorders		Hypertension
Respiratory, thoracic and mediastinal disorders		Allergic rhinitis
Gastrointestinal disorders		Gastritis
Skin and subcutaneous tissue disorders		Rash, pruritus
Musculoskeletal and connective tissue disorders	Arthralgia	Musculoskeletal stiffness
General disorders and administration site conditions	Injection-related reactions	Peripheral oedema
Investigations	White blood cell count decreased	Neutrophil count decreased platelet count decreased, transaminases increased, blood bilirubin increased, weight increased

Description of selected adverse reactions

Injection-related reactions (IRRs)

IRRs reported in patients treated with satralizumab were predominantly mild to moderate, and most occurred within 24 hours after injections. The most commonly reported systemic symptoms were diarrhoea and headache. The most commonly reported local injection site reactions were flushing, erythema, pruritus, rash and pain.

Body weight

In the double-blinded treatment period, body weight increase $\geq 15\%$ from baseline were observed in 3.8% of patients treated with satralizumab (monotherapy or in combination with IST) as compared with 2.7% of patients receiving placebo (or plus IST).

Laboratory abnormalities

Neutrophils

In the double-blinded treatment period, decreased neutrophils were observed in 31.7% of patients treated with satralizumab (monotherapy or in combination with IST) as compared with 21.6% of patients receiving placebo (or placebo plus IST). The majority of neutrophil decreases were transient or intermittent.

9.6% of patients receiving satralizumab had neutrophils below $1 \times 10^9/L$, compared with 5.4% receiving placebo (or placebo plus IST).

Platelets

In the double-blinded treatment period, decreases in platelet count (below $150 \times 10^9/l$) occurred in 24.0% of patients on satralizumab (monotherapy or in combination with IST) as compared with 9.5% of patients receiving placebo or placebo plus IST. The decreased platelet count was not associated with bleeding events.

The majority of the decreased platelets were transient and not below $75 \times 10^9/l$.

Liver enzymes

In the double-blinded treatment period, elevations in ALT or AST occurred in 27.9% and 18.3% of patients treated with satralizumab (monotherapy or in combination with IST) respectively, compared with 12.2% and 13.5% of patients receiving placebo or placebo plus IST. The majority of the elevations were below 3 x ULN, were transient and resolved without interruption of satralizumab.

Elevations in ALT or AST >3 x ULN occurred in 2.9% and 1.9% of patients treated with satralizumab (monotherapy or in combination with IST) respectively. These elevations were not associated with increases in total bilirubin.

Elevations of ALT above 5 x ULN were observed 4 weeks after initiation of therapy in one (1%) patient receiving satralizumab in combination with IST; normalising after discontinuation of treatment, and satralizumab was not reintroduced in this patient (see sections 4.2 and 4.4).

Lipid parameters

In the double-blinded treatment period, 10.6% of patients receiving satralizumab (monotherapy or in combination with IST) experienced elevations in total cholesterol above 7.75 mmol/l as compared with 1.4% of patients receiving placebo (or placebo plus IST); 20.2% of patients receiving satralizumab experienced elevations in triglycerides above 3.42 mmol/l as compared with 10.8% of patients receiving placebo.

Paediatric population

The safety and efficacy of satralizumab have been studied in 9 children ≥ 12 years of age. Frequency, type and severity of adverse reactions in children from 12 years of age are expected to be the same as in adults.

Reporting of suspected adverse reactions

Reporting suspected adverse reactions after authorisation of the medicinal product is important. It allows continued monitoring of the benefit/risk balance of the medicinal product. Healthcare

professionals are asked to report any suspected adverse reactions via [the national reporting system listed in Appendix V](#).

4.9 Overdose

In the event of an overdose, the patient should be closely supervised, treated symptomatically, and supportive measures instituted as required.

5. PHARMACOLOGICAL PROPERTIES

5.1 Pharmacodynamic properties

Pharmacotherapeutic group: immunosuppressants, interleukin inhibitors, ATC code: L04AC19

Mechanism of action

Satralizumab is a recombinant humanised immunoglobulin G2 (IgG2) monoclonal antibody (mAb) that binds to soluble and membrane-bound human IL-6 receptor (IL-6R) and thereby prevents IL-6 downstream signalling through these receptors.

IL-6 levels are increased in cerebrospinal fluid and serum of patients with NMO and NMOSD during periods of disease activity. IL-6 functions have been implicated in the pathogenesis of NMO and NMOSD, including B-cell activation, differentiation of B-cells to plasmablasts and production of pathological autoantibodies, e.g. against AQP4, a water channel protein mainly expressed by astrocytes in the CNS, Th17-cell activation and differentiation, T-regulatory cell inhibition, and changes in blood-brain-barrier permeability.

Pharmacodynamic effects

In clinical studies with satralizumab in NMO and NMOSD, decreases in C-reactive protein (CRP), fibrinogen and complement (C3, C4 and CH50) were observed.

Clinical efficacy and safety

The efficacy and safety of satralizumab were evaluated in two pivotal phase III clinical trials in patients with NMOSD (diagnosed as AQP4-IgG seropositive or seronegative NMO [Wingerchuck 2006 criteria], or as AQP4-IgG seropositive NMOSD [Wingerchuck 2007 criteria]).

Study BN40898 included adult and adolescent NMOSD patients aged 12-74 years treated with stable IST, with at least 2 relapses in the last 2 years prior screening (with at least one relapse within the 12 months prior to screening) and expanded disability status scale (EDSS) of 0 to 6.5, whereas study BN40900 included adult patients aged 18-74 years on no background IST, with at least 1 relapse or first attack within the last 12 months prior to screening and EDSS of 0 to 6.5.

Both studies included approximately 30% AQP4-IgG seronegative NMO patients.

Efficacy in both studies was evaluated based on time to first relapse as adjudicated by an independent Clinical Endpoint Committee (CEC), with relapse defined by pre-specified worsening in the EDSS and functional system score (FSS) criteria, evaluated within 7 days after the patient reported symptoms (adjudicated relapse).

Study BN40898 (also known as SA-307JG or SakuraSky)

Study BN40898 was a randomised, multicentre, double-blind, placebo-controlled clinical trial to evaluate the effect of satralizumab in combination with stable IST (OCs up to 15 mg/day [prednisolone equivalent], AZA up to 3 mg/kg/day or MMF up to 3000 mg/day, adolescents received

a combination of AZA and OCs or MMF and OCs). The double blind period of the study included 83 AQP4-IgG seropositive and seronegative patients (76 adults and 7 adolescents). Patients received the first 3 single doses of satralizumab 120 mg or matching placebo by SC injection in the abdominal or femoral region every 2 weeks for the first 4 weeks and once every 4 weeks thereafter.

Study design and baseline characteristics of the study population are presented in table 4.

Table 4: Study design and baseline characteristics in AQP4-IgG seropositive patients for study BN40898

Study name	Study BN40898 (AQP4-IgG seropositive: N=55; ITT*: N=83)	
Study design		
Study population	Adolescent and adult patients with NMO or NMOSD, treated with stable IST Age 12-74 years, ≥ 2 relapses in the last 2 years prior screening (with at least one relapse in the 12 months prior to screening), EDSS of 0 to 6.5	
Study duration for efficacy evaluation	Event-driven** (26 adjudicated relapses) Median follow-up time: satralizumab 139.4 weeks, placebo 40.2 weeks (in ITT: 115.1 weeks and 42.5 weeks, respectively)	
Treatment groups, in 1:1 randomisation	Group A: satralizumab 120 mg SC Group B: placebo	
Baseline characteristics of AQP4-IgG seropositive patients	Satralizumab + IST (n=27)	Placebo + IST (n=28)
Diagnosis, n (%):		
NMO	19 (70.4)	14 (50.0)
NMOSD	8 (29.6)	14 (50.0)
Mean age in years (SD) (Min-Max)	44.4 (15.7) (13 – 73)	43.4 (12.9) (14 – 65)
Elderly (≥ 65 years), n (%)	3 (11.1)	1 (3.6)
Adolescents (≥ 12 to < 18 years), n (%)	1 (3.7)	2 (7.1)
Gender distribution, n (%) male/ n (%) female	0 / 27 (100)	0 / 28 (100)
Immunosuppressive therapy (IST), n (%):		
Oral corticosteroids (OCs)	14 (51.9)	13 (46.4)
Azathioprine (AZA)	11 (40.7)	11 (39.3)
Mycophenolate mofetil (MMF)	1 (3.7)	3 (10.7)
AZA + OCs***	0	0
MMF + OCs***	1 (3.7)	1 (3.6)

* Intention-To-Treat (ITT)

** Patients treated with rescue therapy with no adjudicated relapse were allowed to enter the OLE period of the study and were censored from the primary efficacy analysis

*** Combination allowed for adolescent patients

Study BN40900 (also known as SA-309JG or SakuraStar)

Study BN40900 was a randomised, multicentre, double-blind, placebo-controlled clinical trial to evaluate the effect of satralizumab monotherapy compared to placebo. The study included 95 AQP4-IgG seropositive and seronegative adult patients. Patients received the first 3 single doses of satralizumab 120 mg or matching placebo by SC injection in the abdominal or femoral region every 2 weeks for the first 4 weeks and once every 4 weeks thereafter.

Study design and baseline characteristics of the study population are presented in table 5.

Table 5: Study design and baseline characteristics in AQP4-IgG seropositive patients for study BN40900

Study name	Study BN40900 (AQP4-IgG seropositive: N=64; ITT*: N=95)	
Study design		
Study population	Adult patients with NMO or NMOSD Age 18-74 years, ≥ 1 relapse or first attack in the last 12 months prior to screening, EDSS of 0 to 6.5. Patients either received prior relapse prevention treatment for NMOSD or were treatment naïve	
Study duration for efficacy evaluation	Event-driven (44 adjudicated relapses, or 1.5 years after the date of randomisation of the last patient enrolled, whichever comes first) Median follow-up time: satralizumab 96.7 weeks, placebo 60.1 weeks (in ITT: 95.4 weeks and 60.5 weeks, respectively)	
Treatment groups, in 2:1 randomisation	Monotherapy: Group A: satralizumab 120 mg SC Group B: placebo	
Baseline characteristics of AQP4-IgG seropositive patients	Satralizumab (n=41)	Placebo (n=23)
Diagnosis, n (%):		
NMO	26 (63.4)	15 (65.2)
NMOSD	15 (36.6)	8 (34.8)
Mean age in years (SD) (Min-Max)	46.0 (12.0) (22 – 70)	40.1 (11.5) (20 – 56)
Elderly (≥ 65 years), n (%)	1 (2.4)	0
Gender distribution, n (%) male/ n (%) female	10 (24.4) / 31 (75.6)	1 (4.3) / 22 (95.7)

* Intention-To-Treat (ITT)

Primary efficacy

In AQP4-IgG seropositive patients the relative risk of experiencing an adjudicated relapse in study BN40898 was reduced by 79% (Hazard Ratio, HR [95% CI]: 0.21 [0.06-0.75]), in study BN40900 by 74% (HR [95% CI]: 0.26 [0.11-0.63]) (see Figures 1 and 2). When data across studies BN40898 and BN40900 were pooled, treatment with satralizumab with or without IST led to an overall risk reduction of 75% (HR [95% CI]; 0.25 (0.12-0.50)) in AQP4-IgG seropositive patients. At 48 weeks, 85.7% of satralizumab-treated AQP4-IgG seropositive patients remained adjudicated relapse-free when used in combination with IST or as monotherapy compared to 58.7% in the placebo group. At 96 weeks, 81.4% of satralizumab-treated AQP4-IgG seropositive patients remained adjudicated

relapse-free when used in combination with IST or as monotherapy compared to 47.2% in the placebo group. Efficacy was not significant in AQP4-IgG seronegative patients.

Figure 1: Study BN40898 - time to first adjudicated relapse during the double-blind period in AQP4-IgG seropositive patients

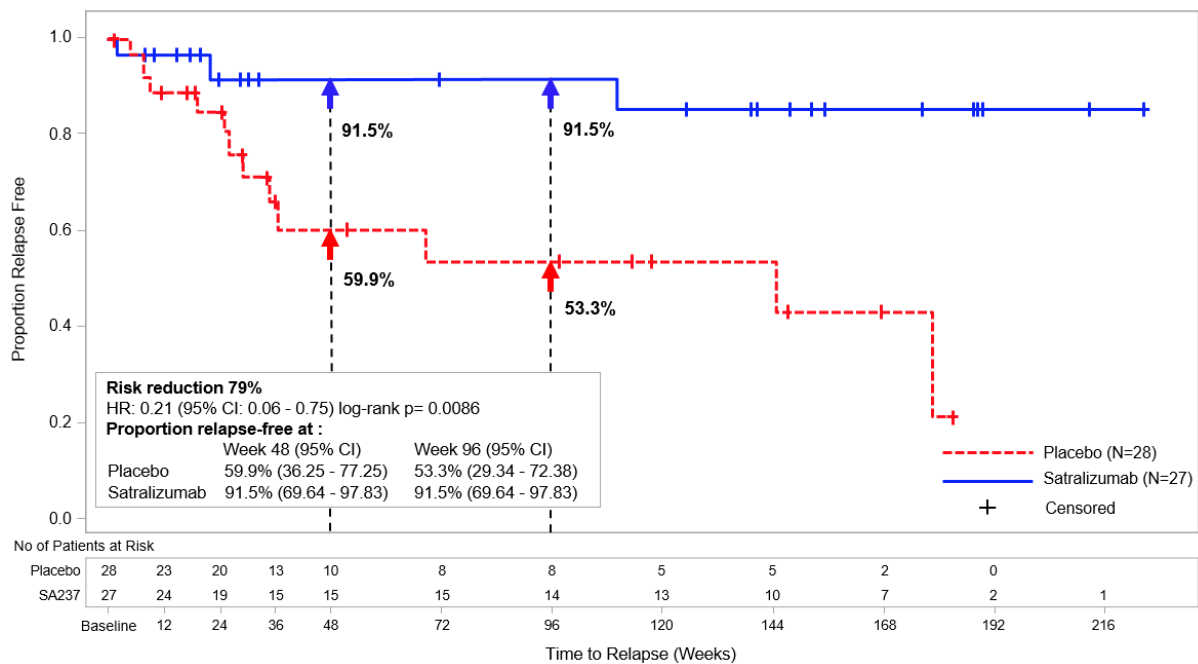
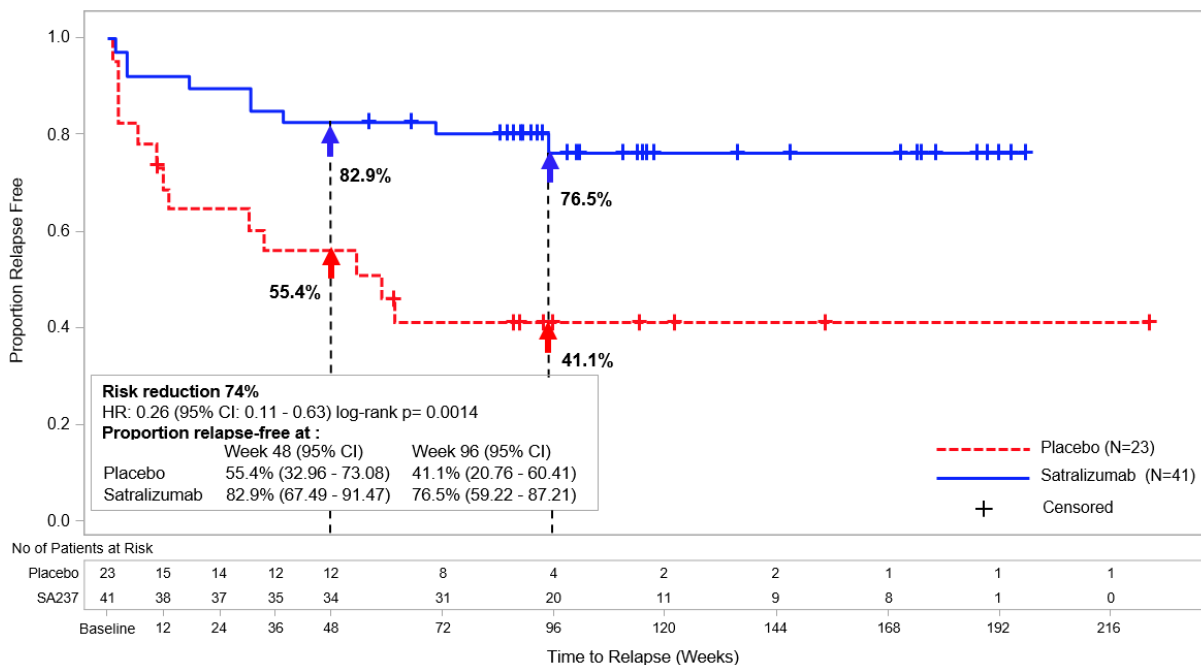

Figure 2: Study BN40900 - time to first adjudicated relapse during the double-blind period in AQP4-IgG seropositive patients



Treatment with satralizumab in AQP4-IgG seropositive patients reduced the annualized rate of adjudicated relapses (ARR) by 88% (rate ratio [RR]=0.122, 95% CI: 0.027 - 0.546; p=0.0039) in study BN40898 and 90% (RR=0.096, 95% CI: 0.020 - 0.473; p= 0.0086) in study BN40900 compared to treatment with placebo.

As compared to placebo-treated patients, the need for rescue therapy (e.g., corticosteroids, intravenous immunoglobulin, and/or apheresis [including plasmapheresis or plasma exchange]) was reduced in satralizumab-treated AQP4-IgG seropositive patients by 61% (odds ratio [OR]= 0.3930, 95% CI: 0.1343 -1.1502; p=0.0883) in study BN40898 and by 74% (OR = 0.2617, 95% CI: 0.0862 - 0.7943; p=0.0180) in study BN40900.

Treatment with satralizumab in AQP4-IgG seropositive patients reduced the risk of experiencing a severe relapse defined as an EDSS increase ≥ 2 points from the previous EDSS assessment by 85% (time to severe adjudicated relapse during the double blind period; HR=0.15, 95% CI: 0.02 -1.25; p=0.0441) in study BN40898 and by 79% (HR=0.21, 95% CI: 0.05 - 0.91; p=0.0231) in study BN40900 compared to treatment with placebo.

Key secondary endpoints

Change from baseline to week 24 in pain or fatigue were not met in studies BN40898 and BN40900.

Open-label extension

Analyses of longer term data including the OLE period (based on relapse treated with rescue therapy) showed that 58% and 73% of AQP4-IgG seropositive patients treated with satralizumab remained relapse-free after 120 weeks of treatment, when satralizumab was administered as add-on therapy or as monotherapy, respectively.

Immunogenicity

In phase III study BN40898 (in combination with IST) and in phase III study BN40900 (in monotherapy), anti-drug-antibodies (ADAs) were observed in 41% and 71% of patients receiving satralizumab in the double-blind period, respectively. The ability of ADAs to neutralise satralizumab binding is unknown.

Exposure was lower in ADA positive patients, however there was no impact of ADAs on safety and no clear impact on efficacy nor pharmacodynamic markers indicative of target engagement.

Treatment with satralizumab led to a similar reduction in the risk of experiencing an adjudicated relapse in patients in the phase III studies despite different ADA rates between those studies.

Paediatric population

In study BN40898, there were 7 adolescent patients enrolled during the double blind period. Their mean age was 15.4 years and the median body weight was 79.6 kg. The majority were female (n=6). Four patients were White, 2 were Black/African American, and 1 was Asian. Three (42.9%) adolescent patients were AQP4-IgG seropositive at screening (2 in the placebo group and 1 in the satralizumab group). During the double-blind period, 1 of 3 adolescents in the placebo group and 1 of 4 adolescents in the satralizumab group experienced an adjudicated relapse. Due to the small sample size, the hazard ratio for the primary endpoint of time to first adjudicated relapse in this subgroup was not calculated. Two additional adolescent patients were enrolled in the open-label period of the study.

The European Medicines Agency has deferred the obligation to submit the results of studies with Enspryng in one or more subsets of the paediatric population in treatment of NMOSD (see section 4.2 for information on paediatric use).

5.2 Pharmacokinetic properties

The pharmacokinetics of satralizumab have been characterised both in Japanese and Caucasian healthy volunteers, and in NMO and NMOSD patients. The pharmacokinetics in NMO and NMOSD patients using the recommended dose were characterised using population PK analysis methods based on a database of 154 patients.

The concentration-time course of satralizumab in patients with NMO or NMOSD was accurately described by a two-compartment population PK model with parallel linear and target-mediated (Michaelis-Menten) elimination and first-order SC absorption. Satralizumab clearance and volume parameters allometrically scaled by body weight (through power function with the fixed power coefficient of 0.75 and 1 for clearance and volume parameters, respectively). Bodyweight was shown to be a significant covariate, with clearance and Vc for patients weighing 123 kg (97.5th percentile of the weight distribution) increased by 71.3% and 105%, respectively, compared to a 60 kg patient.

Steady state pharmacokinetics were achieved after the loading period (8 weeks) for C_{\min} , C_{\max} and AUC as follows (mean (\pm SD): C_{\min} : 19.7 (12.2) mcg/mL, C_{\max} : 31.5 (14.9) mcg/mL and AUC: 737 (386) mcg. mL/day.

Absorption

The absorption rate constant of satralizumab was 0.0104/h equating to an absorption half-life of around 3 days (66 hours) at the recommended dose (see section 4.2). The bioavailability was high (85.4%).

Distribution

Satralizumab undergoes biphasic distribution. The central volume of distribution was 3.46 L, the peripheral volume of distribution was 2.07 L. The inter-compartmental clearance was 14 mL/h.

Biotransformation

The metabolism of satralizumab has not been directly studied, as monoclonal antibodies are principally cleared by catabolism.

Elimination

The total clearance of satralizumab is concentration-dependent. Linear clearance (accounting for approximately half of the total clearance at steady state using the recommended dose in NMO and NMOSD patients) is estimated to be 2.50 mL/h. The associated terminal $t_{1/2}$ is approximately 30 days (range 22-37 days) based on data pooled from the phase 3 studies.

Special populations

Population pharmacokinetic analyses in adult patients with NMO or NMOSD showed that age, gender, and race did not meaningfully influence the pharmacokinetics of satralizumab. Although body weight influenced the pharmacokinetics of satralizumab, no dose adjustments are recommended for any of these demographics.

Paediatric population

Data obtained in 8 adolescent patients [13-17 years of age] who received the adult dosing regimen show that population PK parameters for satralizumab are not significantly different from those in the adult population. Therefore, no dose adjustment is necessary.

Elderly

No dedicated studies have been conducted to investigate the PK of satralizumab in patients ≥ 65 years of age, however patients with NMO or NMOSD between 65 and 74 years of age were included in the BN40898 and BN40900 clinical studies.

Renal impairment

No formal study of the effect of renal impairment on the PK of satralizumab has been conducted. However, patients with mild renal impairment (creatinine clearance ≥ 50 mL/min and < 80 mL/min) were included in the phase III studies. Based on population PK analysis there is no impact of renal impairment on the PK of satralizumab which is in line with the known mechanisms of clearance for satralizumab. Therefore no dose adjustment is required.

Hepatic impairment

No formal study of the effect of hepatic impairment on the PK of satralizumab has been conducted (see section 4.2).

5.3 Preclinical safety data

Non-clinical data reveal no special hazard for humans based on conventional studies of safety pharmacology, repeated dose toxicity and toxicity to reproduction and development.

Carcinogenicity

No rodent carcinogenicity studies have been performed to establish the carcinogenic potential of satralizumab. Proliferative lesions have not been observed in a chronic cynomolgus monkey 6-month toxicity study.

Genotoxicity

No studies have been performed to establish the mutagenic potential of satralizumab. Antibodies are not expected to cause effects on DNA.

Reproductive toxicity

Prenatal treatment and postnatal exposure with satralizumab in pregnant monkeys and their offspring did not elicit any adverse effects on maternal animals, foetal development, pregnancy outcome or infant survival and development including learning ability.

The concentrations of satralizumab in breast milk were very low ($< 0.9\%$ of the corresponding maternal plasma levels).

Fertility

No effects on male or female reproductive organs were seen with chronic treatment of satralizumab in monkeys.

Cytokine release syndrome

Based on *in vitro* studies with human blood, the risk of the release of pro-inflammatory cytokines with satralizumab is considered low in terms of incidence and increase in cytokines.

6. PHARMACEUTICAL PARTICULARS

6.1 List of excipients

Histidine
Aspartic acid
Arginine
Poloxamer 188
Water for injections

6.2 Incompatibilities

In the absence of compatibility studies, this medicinal product must not be mixed with other medicinal products.

6.3 Shelf life

3 years

6.4 Special precautions for storage

Store in a refrigerator (2°C – 8°C).
Do not freeze. Do not use the syringe if it has been frozen.
Always keep the syringe dry.

Keep the PFS in the outer carton in order to protect from light and moisture.

If unopened and kept in the outer carton, the syringe may be left out of the refrigerator below 30°C for a single period up to 8 days. After storage at room temperature the product should not be returned to the refrigerator and should be either used or discarded.

6.5 Nature and contents of container

1 mL solution in a PFS (polymer) with a staked-in, stainless steel needle, fitted with a chlorinated butyl rubber-polypropylene rigid needle shield and sealed with a chlorinated butyl rubber plunger stopper. The PFS is labelled and assembled with an automatic needle guard, plunger rod, and extended finger flanges (EFF).

Pack size of 1 PFS and multipack of 3 (3 packs of 1) PFS. Not all pack sizes may be marketed.

6.6 Special precautions for disposal and other handling

After removing the carton from the refrigerator, the sealed carton should be open and the PFS carefully lifted out of the carton by holding the barrel. It is important to let the PFS reach room temperature by waiting for 30 minutes before initiating the administration process.

The medicinal product should not be used if the liquid is cloudy, discoloured, has visible particles in it or if any part of the PFS appears to be damaged.

The injection must be performed right after removing the cap and no later than 5 minutes, to prevent the medicinal product from drying out and blocking the needle. If the pre-filled syringe is not used within 5 minutes of removing the cap, you must dispose of it in a puncture resistant container and use a new pre-filled syringe.

Any unused medicinal product or waste material should be disposed of in accordance with local requirements.

7. MARKETING AUTHORISATION HOLDER

Roche Registration GmbH
Emil-Barell-Strasse 1
79639 Grenzach-Wyhlen
Germany

8. MARKETING AUTHORISATION NUMBER(S)

EU/1/21/1559/001
EU/1/21/1559/002

9. DATE OF FIRST AUTHORISATION/RENEWAL OF THE AUTHORISATION

Date of first authorisation: 24 June 2021

10. DATE OF REVISION OF THE TEXT

Detailed information on this medicinal product is available on the website of the European Medicines Agency <http://www.ema.europa.eu>.

ANNEX II

- A. MANUFACTURER(S) OF THE BIOLOGICAL ACTIVE SUBSTANCE(S) AND MANUFACTURER(S) RESPONSIBLE FOR BATCH RELEASE**
- B. CONDITIONS OR RESTRICTIONS REGARDING SUPPLY AND USE**
- C. OTHER CONDITIONS AND REQUIREMENTS OF THE MARKETING AUTHORISATION**
- D. CONDITIONS OR RESTRICTIONS WITH REGARD TO THE SAFE AND EFFECTIVE USE OF THE MEDICINAL PRODUCT**

A. MANUFACTURER(S) OF THE BIOLOGICAL ACTIVE SUBSTANCE(S) AND MANUFACTURER(S) RESPONSIBLE FOR BATCH RELEASE

Name and address of the manufacturer(s) of the biological active substance(s)

Chugai Pharma Manufacturing Co., Ltd.
(CPMC) 5-1, Ukima 5-Chome, Kita-ku,
Tokyo, 115-8543
Japan

Name and address of the manufacturer(s) responsible for batch release

Roche Pharma AG
Emil-Barell-Strasse 1
79639 Grenzach-Wyhlen
Germany

B. CONDITIONS OR RESTRICTIONS REGARDING SUPPLY AND USE

Medicinal product subject to restricted medical prescription (see Annex I: Summary of Product Characteristics, section 4.2).

C. OTHER CONDITIONS AND REQUIREMENTS OF THE MARKETING AUTHORISATION

- **Periodic safety update reports (PSURs)**

The requirements for submission of PSURs for this medicinal product are set out in the list of Union reference dates (EURD list) provided for under Article 107c(7) of Directive 2001/83/EC and any subsequent updates published on the European medicines web-portal.

The marketing authorisation holder (MAH) shall submit the first PSUR for this product within 6 months following authorisation.

D. CONDITIONS OR RESTRICTIONS WITH REGARD TO THE SAFE AND EFFECTIVE USE OF THE MEDICINAL PRODUCT

- **Risk management plan (RMP)**

The marketing authorisation holder (MAH) shall perform the required pharmacovigilance activities and interventions detailed in the agreed RMP presented in Module 1.8.2 of the marketing authorisation and any agreed subsequent updates of the RMP.

An updated RMP should be submitted:

- At the request of the European Medicines Agency;
- Whenever the risk management system is modified, especially as the result of new information being received that may lead to a significant change to the benefit/risk profile or as the result of an important (pharmacovigilance or risk minimisation) milestone being reached.

- **Additional risk minimisation measures**

Prior to the launch of Enspryng in each Member State, the Marketing Authorisation Holder (MAH) must agree about the content and format of the patient alert card, distribution modalities, and any other aspects of the card, with the National Competent Authority.

The patient alert card is aimed at intensifying the communication around the risk of infections/serious infections, to ensure that patients seek early medical attention in case of signs and symptoms of infections to facilitate timely diagnosis of infections, and that the healthcare professionals are aware of the need for timely and appropriate measures.

The MAH shall ensure that in each Member State where Enspryng is marketed, all healthcare professionals and patients/carers who are expected to prescribe, dispense, administer or use Enspryng have access to/are provided with the patient alert card.

The patient alert card contains:

- information that Enspryng treatment may increase the risk of infections
- a warning message on seeking early medical care in case of signs or symptoms of infections
- a warning message for healthcare professionals treating the patient at any time, including in conditions of emergency, that the patient is using Enspryng
- contact details of the Enspryng prescriber

ANNEX III
LABELLING AND PACKAGE LEAFLET

A. LABELLING

PARTICULARS TO APPEAR ON THE OUTER PACKAGING

OUTER CARTON

1. NAME OF THE MEDICINAL PRODUCT

Enspryng 120 mg solution for injection in pre-filled syringe
satralizumab

2. STATEMENT OF ACTIVE SUBSTANCE(S)

Each pre-filled syringe contains 120 mg satralizumab

3. LIST OF EXCIPIENTS

Excipients: histidine, aspartic acid, arginine, poloxamer 188, water for injections.

4. PHARMACEUTICAL FORM AND CONTENTS

Solution for injection
1 pre-filled syringe
120 mg/1 mL

5. METHOD AND ROUTE(S) OF ADMINISTRATION

Read the package leaflet before use

Subcutaneous use

For single use only

Allow the syringe to sit at room temperature outside the box for 30 minutes before use

6. SPECIAL WARNING THAT THE MEDICINAL PRODUCT MUST BE STORED OUT OF THE SIGHT AND REACH OF CHILDREN

Keep out of the sight and reach of children

7. OTHER SPECIAL WARNING(S), IF NECESSARY

8. EXPIRY DATE

EXP

9. SPECIAL STORAGE CONDITIONS

Store in a refrigerator

Do not freeze

Keep the pre-filled syringe in the outer carton in order to protect from light and moisture

If unopened and kept in the outer carton, Enspryng may be left out of the refrigerator below 30°C for a single period up to 8 days

10. SPECIAL PRECAUTIONS FOR DISPOSAL OF UNUSED MEDICINAL PRODUCTS OR WASTE MATERIALS DERIVED FROM SUCH MEDICINAL PRODUCTS, IF APPROPRIATE

11. NAME AND ADDRESS OF THE MARKETING AUTHORISATION HOLDER

Roche Registration GmbH
Emil-Barell-Strasse 1
79639 Grenzach-Wyhlen
Germany

12. MARKETING AUTHORISATION NUMBER(S)

EU/1/21/1559/001 1 pre-filled syringe

13. BATCH NUMBER

Lot

14. GENERAL CLASSIFICATION FOR SUPPLY

15. INSTRUCTIONS ON USE

16. INFORMATION IN BRAILLE

enspryng 120 mg

17. UNIQUE IDENTIFIER – 2D BARCODE

2D barcode carrying the unique identifier included

18. UNIQUE IDENTIFIER - HUMAN READABLE DATA

PC
SN
NN

PARTICULARS TO APPEAR ON THE OUTER PACKAGING

OUTER CARTON (WITH BLUE BOX) - MULTIPACK

1. NAME OF THE MEDICINAL PRODUCT

Enspryng 120 mg solution for injection in pre-filled syringe
satralizumab

2. STATEMENT OF ACTIVE SUBSTANCE(S)

Each pre-filled syringe contains 120 mg satralizumab

3. LIST OF EXCIPIENTS

Excipients: histidine, aspartic acid, arginine, poloxamer 188, water for injections.

4. PHARMACEUTICAL FORM AND CONTENTS

Solution for injection
Multipack: 3 (3 packs of 1) pre-filled syringes
120 mg/1 mL

5. METHOD AND ROUTE(S) OF ADMINISTRATION

Read the package leaflet before use

Subcutaneous use

For single use only

Allow the syringe to sit at room temperature outside the box for 30 minutes before use

6. SPECIAL WARNING THAT THE MEDICINAL PRODUCT MUST BE STORED OUT OF THE SIGHT AND REACH OF CHILDREN

Keep out of the sight and reach of children

7. OTHER SPECIAL WARNING(S), IF NECESSARY

8. EXPIRY DATE

EXP

9. SPECIAL STORAGE CONDITIONS

Store in a refrigerator

Do not freeze

Keep the pre-filled syringe in the outer carton in order to protect from light and moisture

If unopened and kept in the outer carton, Enspryng may be left out of the refrigerator below 30°C for a single period up to 8 days

10. SPECIAL PRECAUTIONS FOR DISPOSAL OF UNUSED MEDICINAL PRODUCTS OR WASTE MATERIALS DERIVED FROM SUCH MEDICINAL PRODUCTS, IF APPROPRIATE**11. NAME AND ADDRESS OF THE MARKETING AUTHORISATION HOLDER**

Roche Registration GmbH
Emil-Barell-Strasse 1
79639 Grenzach-Wyhlen
Germany

12. MARKETING AUTHORISATION NUMBER(S)

EU/1/21/1559/002 3 prefilled-syringes (3 packs of 1)

13. BATCH NUMBER

Lot

14. GENERAL CLASSIFICATION FOR SUPPLY**15. INSTRUCTIONS ON USE****16. INFORMATION IN BRAILLE**

enspryng 120 mg

17. UNIQUE IDENTIFIER – 2D BARCODE

2D barcode carrying the unique identifier included

18. UNIQUE IDENTIFIER - HUMAN READABLE DATA

PC
SN
NN

PARTICULARS TO APPEAR ON THE OUTER PACKAGING

INNER CARTON (WITHOUT BLUE BOX) - MULTIPACK

1. NAME OF THE MEDICINAL PRODUCT

Enspryng 120 mg solution for injection in pre-filled syringe
satralizumab

2. STATEMENT OF ACTIVE SUBSTANCE(S)

Each pre-filled syringe contains 120 mg satralizumab

3. LIST OF EXCIPIENTS

Excipients: histidine, aspartic acid, arginine, poloxamer 188, water for injections.

4. PHARMACEUTICAL FORM AND CONTENTS

Solution for injection

1 pre-filled syringe. Component of a multipack, can't be sold separately.
120 mg/1 mL

5. METHOD AND ROUTE(S) OF ADMINISTRATION

Read the package leaflet before use

Subcutaneous use

For single use only

Allow the syringe to sit at room temperature outside the box for 30 minutes before use

6. SPECIAL WARNING THAT THE MEDICINAL PRODUCT MUST BE STORED OUT OF THE SIGHT AND REACH OF CHILDREN

Keep out of the sight and reach of children

7. OTHER SPECIAL WARNING(S), IF NECESSARY

8. EXPIRY DATE

EXP

9. SPECIAL STORAGE CONDITIONS

Store in a refrigerator

Do not freeze

Keep the pre-filled syringe in the outer carton in order to protect from light and moisture

If unopened and kept in the outer carton, Enspryng may be left out of the refrigerator below 30°C for a single period up to 8 days

10. SPECIAL PRECAUTIONS FOR DISPOSAL OF UNUSED MEDICINAL PRODUCTS OR WASTE MATERIALS DERIVED FROM SUCH MEDICINAL PRODUCTS, IF APPROPRIATE**11. NAME AND ADDRESS OF THE MARKETING AUTHORISATION HOLDER**

Roche Registration GmbH
Emil-Barell-Strasse 1
79639 Grenzach-Wyhlen
Germany

12. MARKETING AUTHORISATION NUMBER(S)

EU/1/21/1559/002 3 pre-filled syringes (3 packs of 1)

13. BATCH NUMBER

Lot

14. GENERAL CLASSIFICATION FOR SUPPLY**15. INSTRUCTIONS ON USE****16. INFORMATION IN BRAILLE**

enspryng 120 mg

17. UNIQUE IDENTIFIER – 2D BARCODE

2D barcode carrying the unique identifier included

18. UNIQUE IDENTIFIER - HUMAN READABLE DATA

PC
SN
NN

**MINIMUM PARTICULARS TO APPEAR ON SMALL IMMEDIATE PACKAGING UNITS
PRE-FILLED SYRINGE LABEL**

1. NAME OF THE MEDICINAL PRODUCT AND ROUTE(S) OF ADMINISTRATION

Enspryng 120 mg injection
satralizumab
SC

2. METHOD OF ADMINISTRATION

3. EXPIRY DATE

EXP

4. BATCH NUMBER

Lot

5. CONTENTS BY WEIGHT, BY VOLUME OR BY UNIT

120 mg/1 mL

6. OTHER

B. PACKAGE LEAFLET

Package leaflet: Information for the patient

Enspryng 120 mg solution for injection in pre-filled syringe satralizumab

▼ This medicine is subject to additional monitoring. This will allow quick identification of new safety information. You can help by reporting any side effects you may get. See the end of section 4 for how to report side effects.

Read all of this leaflet carefully before you start using this medicine because it contains important information for you.

- Keep this leaflet. You may need to read it again.
- If you have any further questions, ask your doctor, pharmacist or nurse.
- This medicine has been prescribed for you only. Do not pass it on to others. It may harm them, even if their signs of illness are the same as yours.
- If you get any side effects, talk to your doctor, pharmacist or nurse. This includes any possible side effects not listed in this leaflet. See section 4.

In addition to this leaflet, your doctor will also give you a patient alert card, which contains important safety information that you need to be aware of before and during treatment with Enspryng. Keep this alert card with you at all times.

What is in this leaflet

1. What Enspryng is and what it is used for
2. What you need to know before you use Enspryng
3. How to use Enspryng
4. Possible side effects
5. How to store Enspryng
6. Contents of the pack and other information

Instructions for use

1. What Enspryng is and what it is used for

What Enspryng is

Enspryng contains the active substance satralizumab. It is a type of protein called a monoclonal antibody. Monoclonal antibodies are designed to recognise and attach to a specific substance in the body.

What Enspryng is used for

Enspryng is a medicine for treating neuromyelitis optica spectrum disorders (NMOSD) in adults and young people from 12 years of age.

What is NMOSD

NMOSD is a disease of the central nervous system that mainly affects the optic nerves and spinal cord. It is caused by the immune system (the body's defences) working incorrectly and attacking nerves in the body.

- The damage to the optic nerves causes swelling, leading to pain and loss of sight.
- The damage to the spinal cord causes weakness or loss of movement in the legs or arms, loss of feeling, and problems with bladder and bowel function.

In an attack of NMOSD, there is swelling in the nervous system. This also happens when the disease comes back (relapse). The swelling causes new symptoms or a return of previous symptoms.

How Enspryng works

Enspryng blocks the action of a protein called interleukin-6 (IL-6), which is involved in the processes that lead to damage and swelling in the nervous system. By blocking its effects, Enspryng reduces the risk of a relapse or attack of NMOSD.

2. What you need to know before you use Enspryng

Do not use Enspryng

- if you are allergic to satralizumab or any of the other ingredients of this medicine (listed in section 6).

If the above applies to you or you are not sure, do not use Enspryng and talk to your doctor, pharmacist or nurse.

Warnings and precautions

Talk to your doctor immediately if you experience any allergic reaction (see section 4. Possible side effects).

Talk to your doctor, pharmacist or nurse before using Enspryng if any of the below apply to you (or if you are not sure).

Infections

You cannot use Enspryng while you have an infection. **Tell your doctor or nurse straight away if you think you have any signs of infection** before, during, or after Enspryng treatment such as:

- fever or chills
- cough that does not go away
- sore throat
- cold sore or genital sores (herpes simplex)
- shingles (herpes zoster)
- skin redness, swelling, tenderness or pain
- feeling or being sick, diarrhoea or belly pain.

You will also find this information in the patient alert card you have been given by your doctor. It is important that you keep this alert card with you at all times and show it to any doctor, nurse or caregiver.

Your doctor will wait until the infection is controlled before giving you Enspryng or allowing you to continue to inject Enspryng.

Vaccinations

Tell your doctor if you have recently been given any vaccine or might be given a vaccine in the near future.

- Your doctor will check if you need any vaccines before you start Enspryng.
- Do not have live or live attenuated vaccines (for example BCG for tuberculosis or vaccines against yellow fever) while you are being treated with Enspryng.

Liver enzymes

Enspryng can have effects on your liver and increase the amount of some liver enzymes in your blood. Your doctor will do blood tests before you are given Enspryng, and during your treatment, to check how well your liver is working. **Tell your doctor or nurse straight away** if you have any of these signs of liver damage during or after Enspryng treatment:

- yellowing of the skin and the whites of the eyes (jaundice)
- dark-coloured urine
- feeling and being sick
- abdominal pain

White blood cell count

Your doctor will perform blood tests before you are given Enspryng, and during your treatment, to check your white blood cell count.

Children and young people

Do not give this medicine to children under 12 years of age. This is because it has not yet been studied in this age group.

Other medicines and Enspryng

Tell your doctor or pharmacist if you are taking, have recently taken or might take any other medicines.

Tell your doctor or pharmacist if you are taking medicines such as warfarin, carbamazepine, phenytoin and theophylline as doses might need to be adjusted.

Pregnancy and breast-feeding

If you are pregnant or breast-feeding, think you may be pregnant or are planning to have a baby, ask your doctor or pharmacist for advice before taking this medicine.

Your doctor may advise you to stop breast-feeding if you are to be given Enspryng. It is not known whether Enspryng passes into breast milk.

Driving and using machines

Enspryng is not likely to affect you being able to drive, cycle or use any tools or machines.

3. How to use Enspryng

Always use this medicine exactly as your doctor or pharmacist has told you. Check with your doctor or pharmacist if you are not sure.

How much Enspryng to use

Each injection contains 120 mg of satralizumab. The first injection will be given under the supervision of your doctor or nurse.

- The first three injections are given once every 2 weeks. These are called 'loading doses'.
- After this, the injection is given every 4 weeks. This is called the 'maintenance dose'. Continue with the injections once every 4 weeks for as long as your doctor tells you to.

How to use Enspryng

- Enspryng is given by injection under the skin (sub-cutaneously).
- Inject the entire content of the syringe each time.

At the start, your doctor or nurse may inject Enspryng. However, your doctor may decide that you or an adult caregiver can inject Enspryng.

- You or your caregiver will get training on how to inject Enspryng.
- Talk to your doctor or nurse if you or your caregiver have any questions about giving injections.

Read carefully and follow the “Instructions for use” at the end of this leaflet on how to inject Enspryng.

If you use more Enspryng than you should

Because Enspryng is in a pre-filled syringe, it is unlikely that you will receive too much. However, if you are worried, talk to your doctor, pharmacist or nurse.

If you accidentally inject more doses than you should, call your doctor. Always take the outer carton with you when you go to see the doctor.

If you forget to use Enspryng

For the treatment to be fully effective, it is very important to keep having the injections.

If your doctor or nurse is giving your injections and you miss an appointment, make another one straight away.

If you are injecting Enspryng yourself and you miss an injection, inject it as soon as possible. Do not wait until the next planned dose. After you have had the injection for the missed dose, your next injection should be either:

- for loading doses – 2 weeks later
- for maintenance doses – 4 weeks later

Check with your doctor, pharmacist or nurse if you are not sure.

If you stop using Enspryng

Do not suddenly stop using Enspryng without asking your doctor first. If you have any further questions on the use of this medicine, ask your doctor, pharmacist or nurse.

4. Possible side effects

Like all medicines, this medicine can cause side effects, although not everybody gets them.

Allergic reactions

Tell your doctor straight away or go to the emergency department of your nearest hospital, if you have any signs of allergic reactions during or after the injection. They include:

- tight chest or wheezing
- feeling short of breath
- fever or chills
- severe dizziness or light-headedness
- swelling of the lips, tongue, face
- skin itching, hives or rash.

Do not take the next dose until you have spoken with your doctor and your doctor has told you to take the next dose.

Injection-related reactions (very common: may affect more than 1 in 10 people)

In most cases these are mild reactions, but some can be serious.

Tell your doctor or nurse straight away if you have any of these signs during or after the injection, particularly in the first 24 hours after the injection:

- redness, itching, pain or swelling where the injection is given
- rash, red or itchy skin or hives
- feeling flushed
- headache
- throat irritation, swelling or pain
- feeling short of breath
- low blood pressure (dizziness and light-headedness)
- fever or chills
- feeling tired
- feeling or being sick, or diarrhoea
- fast heart rate, fluttering or pounding heart (palpitations).

Tell your doctor or nurse straight away if you have any of the signs above.

Other side effects:

Very common (may affect more than 1 in 10 people)

- headache
- joint pain
- high levels of blood lipids (fats)
- low level of white blood cells in tests

Common (may affect up to 1 in 10 people)

- feeling stiff
- migraine
- slow heart beat (bradycardia)
- increase in blood pressure
- being unable to sleep
- swelling in your lower legs, feet or hands
- rash or itching
- allergies or hay fever
- stomach inflammation (gastritis), including stomach pain and nausea
- weight increase
- blood tests showing:
 - low fibrinogen levels (a protein involved in blood clotting)
 - high level of liver enzymes (transaminases, possible sign of liver problems)
 - high level of bilirubin (possible sign of liver problems)
 - low level of platelets (which may lead to bleeding or bruising easily)

Reporting of side effects

If you get any side effects, talk to your doctor, pharmacist or nurse. This includes any possible side effects not listed in this leaflet. You can also report side effects directly via [the national reporting system](#) listed in [Appendix V](#). By reporting side effects you can help provide more information on the safety of this medicine.

5. How to store Enspryng

- Keep this medicine out of the sight and reach of children.
- Do not use this medicine after the expiry date which is stated on the pre-filled syringe label and carton after 'EXP'. The expiry date refers to the last day of that month.
- Store in a refrigerator (2°C – 8°C). Do not freeze. Do not use the syringe if it has been frozen. Always keep the syringe dry.
- Keep the pre-filled syringes in the outer carton in order to protect from light and moisture.
- If unopened and kept in the outer carton, Enspryng may be left out of the refrigerator below 30°C for a single period up to 8 days. Do not return Enspryng to the refrigerator.
- Do not use and discard the pre-filled syringe if it has been left out of the refrigerator for longer than 8 days.

Do not use this medicine if it is cloudy, discoloured or contains particles. Enspryng is a colourless to slightly yellow liquid.

The medicine must be injected right after removing the cap and no later than 5 minutes to prevent the medicine from drying out and blocking the needle. If the pre-filled syringe is not used within 5 minutes of removing the cap, you must dispose of it in a puncture-resistant container and use a new pre-filled syringe.

Do not throw away any medicines via wastewater or household waste. Ask your pharmacist how to throw away medicines you no longer use. These measures will help protect the environment.

6. Contents of the pack and other information

What Enspryng contains

- The active substance is satralizumab. Each pre-filled syringe contains 120 mg of satralizumab in 1 mL.
- The other ingredients are histidine, aspartic acid, arginine, poloxamer 188, water for injections.

What Enspryng looks like and contents of the pack

- It is a colourless to slightly yellow liquid.
- Enspryng is a solution for injection.
- Each pack of Enspryng contains 1 pre-filled syringe. Each multipack of Enspryng contains 3 (3 packs of 1) pre-filled syringes. Not all pack sizes may be marketed.

Marketing Authorisation Holder

Roche Registration GmbH
Emil-Barell-Strasse 1
79639 Grenzach-Wyhlen
Germany

Manufacturer

Roche Pharma AG
Emil-Barell-Strasse 1
79639 Grenzach-Wyhlen
Germany

For any information about this medicine, please contact the local representative of the Marketing Authorisation Holder:

België/Belgique/Belgien

N.V. Roche S.A.

Tél/Tel: +32 (0) 2 525 82 11

България

Рош България ЕООД

Тел: +359 2 818 44 44

Česká republika

Roche s. r. o.

Tel: +420 - 2 20382111

Danmark

Roche Pharmaceuticals A/S

Tlf: +45 - 36 39 99 99

Deutschland

Roche Pharma AG

Tel: +49 (0) 7624 140

Eesti

Roche Eesti OÜ

Tel: + 372 - 6 177 380

Ελλάδα

Roche (Hellas) A.E.

Τηλ: +30 210 61 66 100

España

Roche Farma S.A.

Tel: +34 - 91 324 81 00

France

Roche

Tél: +33 (0) 1 47 61 40 00

Hrvatska

Roche d.o.o.

Tel: +385 1 4722 333

Ireland

Roche Products (Ireland) Ltd.

Tel: +353 (0) 1 469 0700

Ísland

Roche Pharmaceuticals A/S

c/o Icepharma hf

Sími: +354 540 8000

Italia

Roche S.p.A.

Tel: +39 - 039 2471

Κύπρος

Γ.Α.Σταμάτης & Σια Λτδ.

Τηλ: +357 - 22 76 62 76

Lietuva

UAB "Roche Lietuva"

Tel: +370 5 2546799

Luxembourg/Luxemburg

(Voir/siehe Belgique/Belgien)

Magyarország

Roche (Magyarország) Kft.

Tel: +36 - 12 794 500

Malta

(see Ireland)

Nederland

Roche Nederland B.V.

Tel: +31 (0) 348 438050

Norge

Roche Norge AS

Tlf: +47 - 22 78 90 00

Österreich

Roche Austria GmbH

Tel: +43 (0) 1 27739

Polska

Roche Polska Sp.z o.o.

Tel: +48 - 22 345 18 88

Portugal

Roche Farmacêutica Química, Lda

Tel: +351 - 21 425 70 00

România

Roche România S.R.L.

Tel: +40 21 206 47 01

Slovenija

Roche farmacevtska družba d.o.o.

Tel: +386 - 1 360 26 00

Slovenská republika

Roche Slovensko, s.r.o.

Tel: +421 - 2 52638201

Suomi/Finland

Roche Oy

Puh/Tel: +358 (0) 10 554 500

Sverige

Roche AB

Tel: +46 (0) 8 726 1200

Latvija
Roche Latvija SIA
Tel: +371 - 6 7039831

United Kingdom (Northern Ireland)
Roche Products (Ireland) Ltd.
Tel: +44 (0) 1707 366000

This leaflet was last revised in

Detailed information on this medicine is available on the European Medicines Agency web site:
<http://www.ema.europa.eu>

There are also links to other websites about rare diseases and treatments.

Instructions for use

Read these instructions for use:

- **Before you start using your pre-filled syringe**
- **Each time you get a prescription refill, because it may contain new information.**
- This information does not take the place of talking to your doctor or nurse about your medical condition or treatment.
- Your doctor or nurse will decide if you or a caregiver can give you injections of Enspryng at home. They will also show you or a caregiver the correct and safe way to use the syringe before you use it for the first time.
- Talk to your doctor or nurse if you have any questions.

Important Information

- Each syringe is pre-filled with a medicine called Enspryng.
- Each carton of Enspryng contains only 1 pre-filled syringe.
- Each pre-filled syringe can be used only once.
- Do not share your syringes with other people.
- Do not take the needle cap off until you are ready to inject Enspryng.
- Do not use the syringe if it has been dropped or damaged.
- Do not try to take the syringe apart at any time.
- Do not leave the syringe unattended.
- Do not re-use the same syringe.

Supplies needed to give your injection

Each Enspryng carton contains:

- 1 pre-filled syringe for one-time use only.

You also need the following but they are not included in the carton:

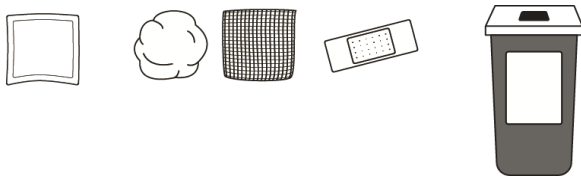

- 1 alcohol pad
 - 1 sterile cotton ball or gauze
 - 1 small bandage
 - 1 puncture-resistant sharps container for safe disposal of the needle cap and used syringe. See step 21 “Disposing of Enspryng” at the end of these instructions for use.
-

Enspryng pre-filled syringe
(See Figure A and Figure B)
Before use:

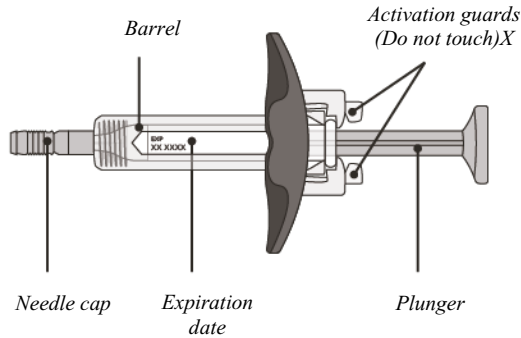

Figure A

After use:

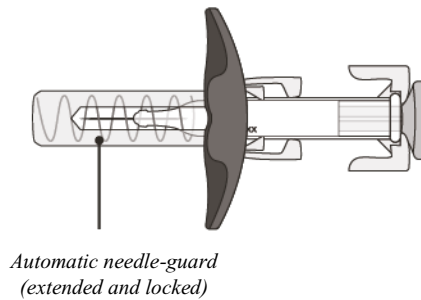

Figure B

The syringe has an automatic needle-guard that covers the needle when the injection is complete.

Prepare to use Enspryng

1. Take the carton containing the syringe out of the refrigerator and place it on a clean, flat work surface (like a table).
2. Check the expiry date on the back of the carton (**see Figure C**). **Do not** use if the carton has expired.
3. Check that the front of the carton is sealed (**see Figure C**). **Do not** use if the seal is broken.

If the expiry date has passed or the seal is broken, go to step 21 “Disposing of Enspryng” and contact your doctor or nurse.

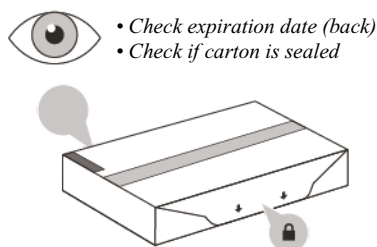

Figure C

4. Open the sealed carton (see **Figure D**).

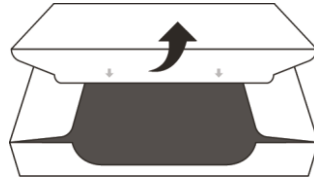

Figure D

5. Carefully lift the syringe out of the carton by holding the barrel (see **Figure E**).
 - Do not turn the carton upside down to remove the syringe.
 - Do not touch the activation guards. This may damage the syringe.
 - Do not hold the plunger or needle cap.

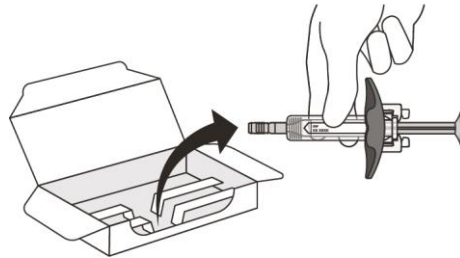

Figure E

Check the syringe

(See **Figure F**)

6. Check the expiry date on the syringe. **Do not** use the syringe if it has expired.
7. Check the syringe for any damage. **Do not** use if it is cracked or broken.
8. Check that the liquid through the viewing window is clear and colourless to slightly yellow. **Do not** inject the medicine if the liquid is cloudy, discoloured, or has particles in it.
 - There may be some small air bubbles in the syringe. This is normal and you should not try to remove them.

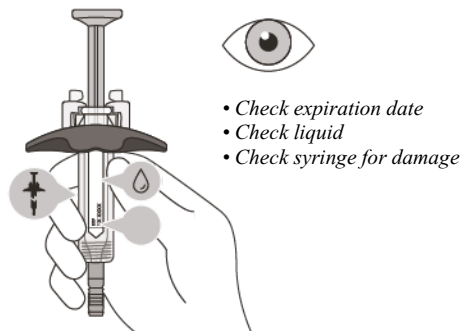

Figure F

If the expiry date has passed, the syringe is damaged or the liquid is cloudy, discoloured or has particles in it, do not use. Then go to step 21 “Disposing of Enspryng” and contact your doctor or nurse.

Let your syringe get to room temperature

9. Once you have checked the syringe, place it on a clean, flat work surface (like a table) for **30 minutes**. This will allow it to reach room temperature (see **Figure G**).

It is important to let the syringe gently reach room temperature because injecting cold medicine may feel uncomfortable and make it harder to push the plunger.

- Do not speed up the warming process by heating the syringe in any way.
- Do not remove the needle cover while the syringe is reaching room temperature.



Wash your hands

10. Wash your hands with soap and water (see **Figure H**).



Figure H

Choose the injection site

11. Choose your injection site in either:

- the lower part of your stomach (abdomen) or,
- the front and middle of your thighs (**see Figure I**).

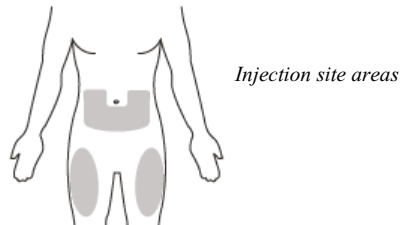

Figure I

- Do not inject into the 5 cm area around your belly button.
- Do not inject into moles, scars, bruises, or areas where the skin is tender, red, hard or broken.

Choose a different injection site for **each new injection**. Choose a different site for each new injection at least **2.5 cm** away from the place used last time.

Clean the injection site

12. Wipe the injection site with an alcohol pad and let it air dry.

- Do not fan or blow on the area which you have cleaned.
- Do not touch the injection site again before you give the injection.



Figure J

Inject Enspryng

13. Hold the barrel of the syringe between your thumb and index finger. With your other hand, pull the needle cap straight off. You may see a drop of liquid at the end of the needle. This is normal and will not affect your dose (**see Figure K**).

- Use the syringe within 5 minutes of removing the cap or the needle may clog.
- Do not take the needle cap off until you are ready to inject Enspryng.
- Do not put the needle cap back on once it has been removed as this may damage the needle.

- Do not touch the needle or let it touch any surfaces after removing the needle cap.

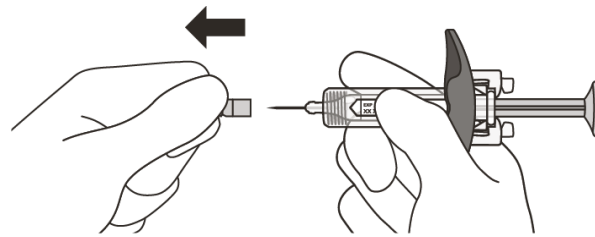

Figure K

14. Throw away the needle cap in a puncture-resistant sharps container immediately. See step 21 “Disposing of Enspryng”.
15. Hold the barrel of the syringe using your thumb and index finger. With your other hand, pinch the area of skin you have cleaned (**see Figure L**).
16. Use a quick, dart-like motion to insert the needle at an angle between 45° to 90° (**see Figure L**).
 - Do not change the angle of the injection while performing the injection.
 - Do not insert the needle again.

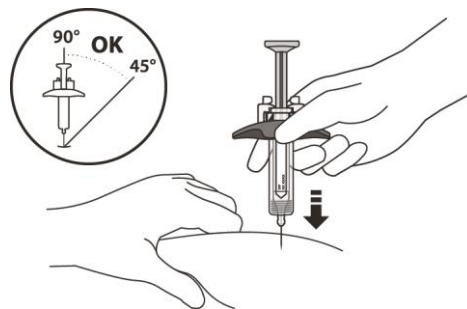

Figure L

17. After the needle is inserted, let go of the pinched skin.

18. Slowly inject all of the medicine by gently pushing the plunger all the way down until it touches the activation guards (**see Figure M**).

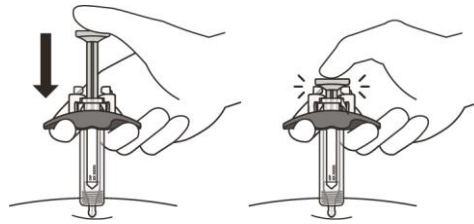

Figure M

19. Gently release the plunger and allow the needle to come out of the skin at the same angle it was inserted (**see Figure N**).

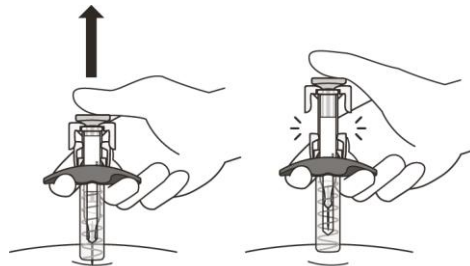

Figure N

- **The needle will now be covered by the automatic needle-guard.** If the needle is not covered, carefully place the syringe into a puncture-resistant sharps container to avoid injury. See step 21 “Disposing of Enspryng”.

Taking care of the injection site

20. There may be a little bleeding at the injection site. You can press a cotton ball or gauze over the injection site until any bleeding stops but **do not** rub it. If needed, you may also cover the area you injected with a small bandage. If the medicine comes into contact with your skin, wash the area with water.

Disposing of Enspryng

21. Do not try to re-cap your syringe. Put your used syringe in a sharps disposal container immediately after use (**see Figure O**). **Do not** throw the syringe in your household waste and do not recycle it.



Figure O

- Ask your doctor or nurse or pharmacist for information about where you can get a "sharps" container or what other types of puncture-resistant containers you can use to safely dispose of your used syringes and needle caps.
- Dispose of the used sharps disposal container as instructed by your healthcare provider or pharmacist .
- Do not dispose of your used sharps disposal container in your household waste.
- Do not recycle your used sharps disposal container.